

# Soupir Poncho - Free Pattern



## Suggested yarn:

- Pierrot Yarns Soupir Wool [53% merino wool, 31% acrylic, 15% tencel/lyocell, 1% silk; 79 yds/72m per 1.41 oz./40g skein]; color #07 olive brown, 29 skeins [1130g]

## Tools/Notions:

- 5.0mm (US H) crochet hook or size necessary to achieve gauge

## Finished measurements:

- Please see schematics.

## Gauge (10cm/4" square):

- pattern stitch: 17 sts and 8 rows

*Gauge may vary according to individual crochet style. Change hook size if necessary to achieve gauge. Alternatively, rework pattern with your own gauge measurements.*

## Summary

✳️**Note:** Like all Japanese patterns, stitch counts given here for foundation chains do not include any chain sts needed for turning posts.

**Body of poncho (make 2):** Work foundation chain to begin, then work in pattern stitch. Place markers where indicated in schematic.

**Finishing:** Referring to finishing schematic, seam the two pieces together with whipstitch. Crochet edging in the round. Make and attach fringe.

## Abbreviations:

ch = chain      dc = double crochet (US)      fp = front post      pm = place marker      RS = right side      tr = treble crochet (US)

## Body of poncho (make 2)

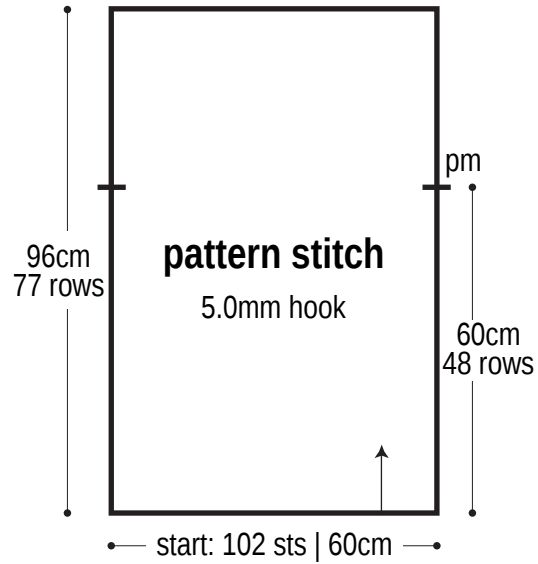

## Finishing

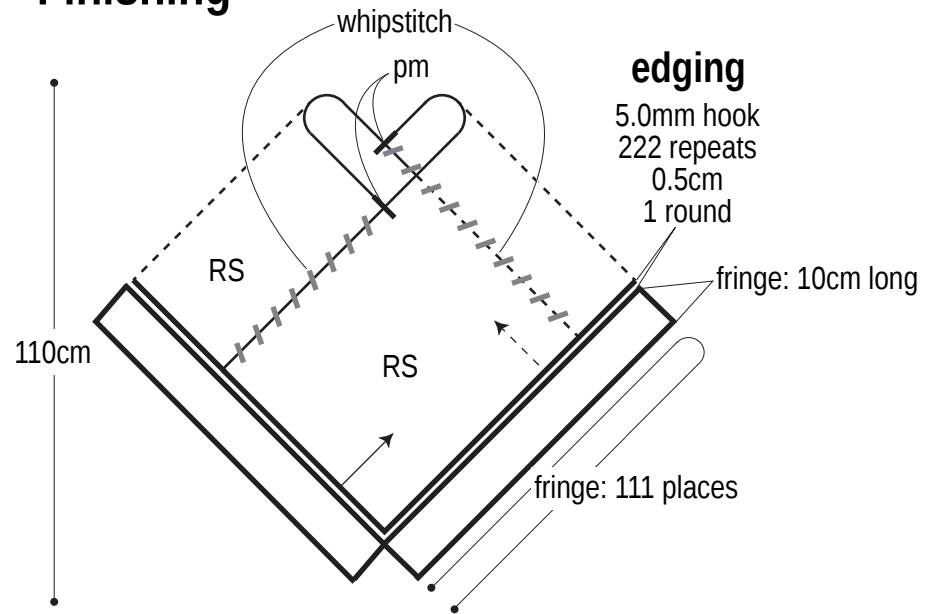

## Edging

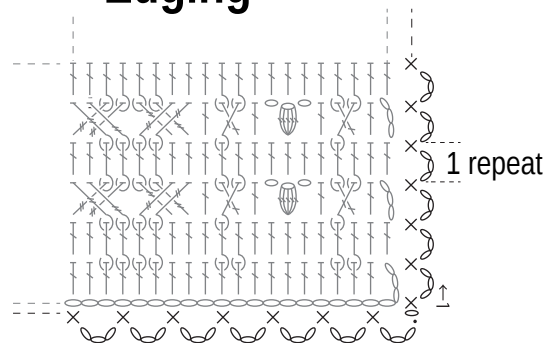

## Fringe

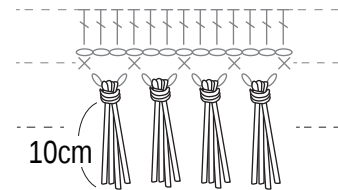

Take 4 strands of yarn, each 22cm long, and tie where indicated. Trim ends neatly. Make 222 fringes total (see finishing schematic for placement).

# Pattern stitch

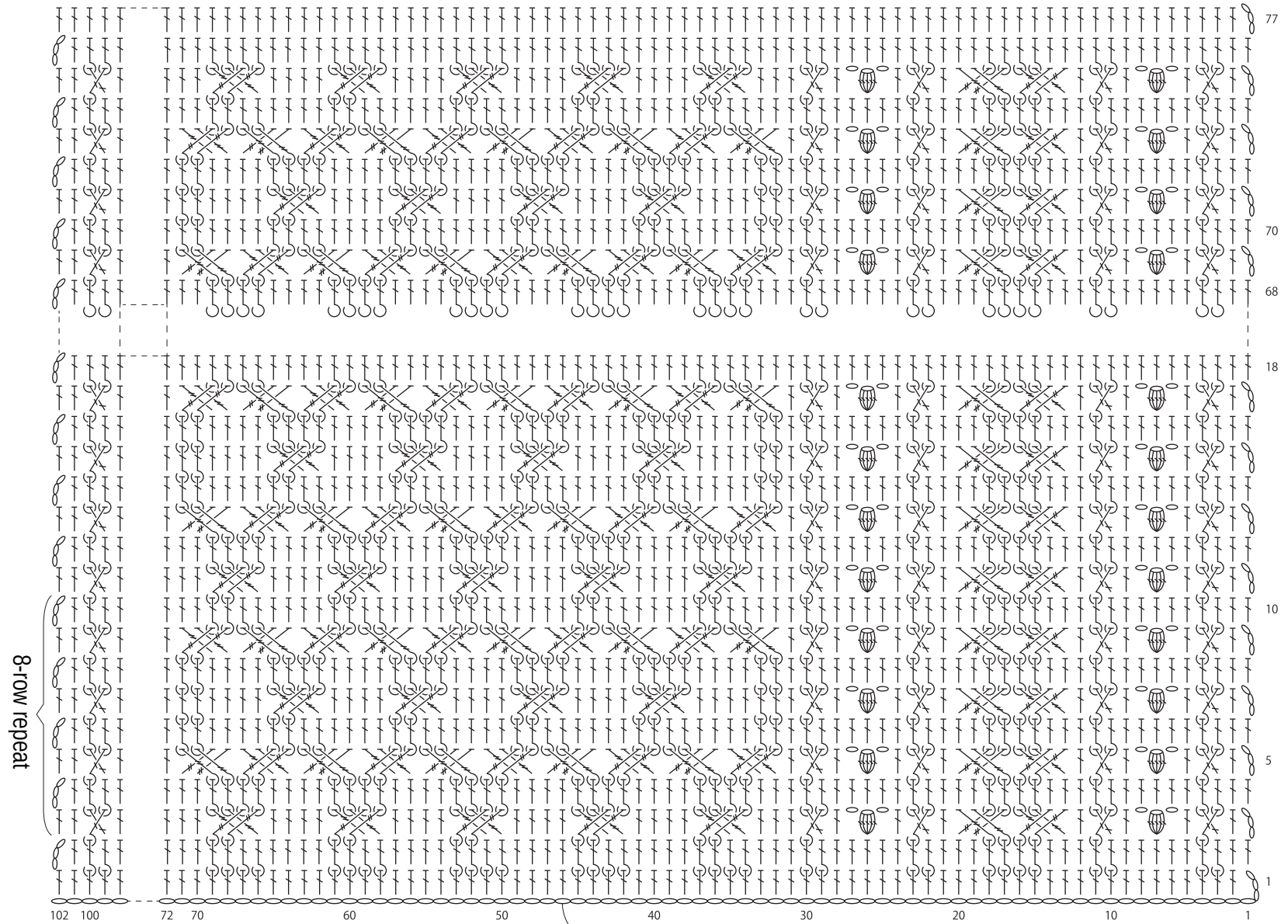

※Stitches 72-101 are the same as stitches 2-31.

ch102 to begin

 = fp dc

 = 5-dc popcorn st

 = fp tr